

Service Manual

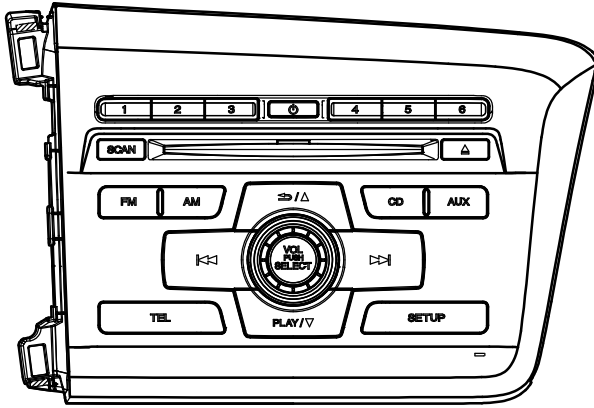

HONDA Motor Genuine
 AM/FM Radio Tuner
 1CD Player

Model **PH-3377C-A**
 (Genuine No. 39100-TS8-A11)
 (ID No. 4BCE)
 (For South America)



This product is a lead free model.
 Lead free solder is used in PWB stamped LF mark.
 Please keep the following conditions when you repair.

1. Use lead free solder.
 - * Koki's lead free solder S3X-55M 0.6mm (CLARION Parts No.642-0231-01)
 - * Koki's lead free solder S3X-55M 1.0mm (CLARION Parts No.642-0231-02)
2. Use a nitrogen solder system.
3. Do not use "General solder" and "Lead free solder" together.

ORIGINAL MODEL

The original model of PH-3377C-A is PH-3312C-A.

Original model	Manual No.
PH-3312C-A	298-6866-00

The following parts are different from the original model.

- * Escutcheon assy
- * Setplate
- * EQ/LOUD Specification (E2P-IC Audio data)

MECHANISM SERVICE MANUAL

Please refer to the following service manual for the CD mechanism.

Original model	Manual No.
929-5033-80	298-6867-00

NOTES

- * The tuner of this model is DSP type. The special equipment is necessary for an accurate adjustment of DSP tuner.
- * This product includes technology owned by Microsoft Corporation and cannot be used or distributed without a license from MSLGP.
- * Specification and design are subject to change without notice for further improvement.

COMPONENTS

PH-3377C-A

1. Main unit
2. Carton
3. Packing
4. Packing
5. Poly-bag
6. Silicagel
7. Label
8. Poly-bag
9. Setplate
10. Protector

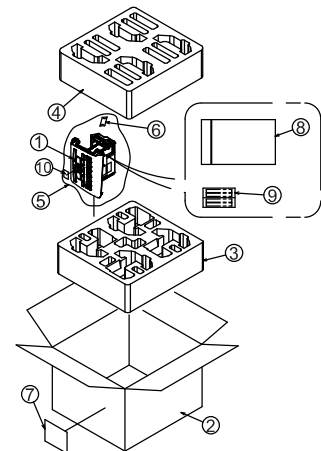

To engineers in charge of repair or inspection of our products.

Before repair or inspection, make sure to follow the instructions so that customers and Engineers in charge of repair or inspection can avoid suffering any risk or injury.

1. Use specified parts.

The system uses parts with special safety features against fire and voltage. Use only parts with equivalent characteristics when replacing them.

The use of unspecified parts shall be regarded as remodeling for which we shall not be liable. The onus of product liability (PL) shall not be our responsibility in cases where an accident or failure is as a result of unspecified parts being used.

2. Place the parts and wiring back in their original positions after replacement or re-wiring.

For proper circuit construction, use of insulation tubes, bonding, gaps to PWB, etc, is involved. The wiring connection and routing to the PWB are specially planned using clamps to keep away from heated and high voltage parts. Ensure that they are placed back in their original positions after repair or inspection.

If extended damage is caused due to negligence during repair, the legal responsibility shall be with the repairing company.

3. Check for safety after repair.

Check that the screws, parts and wires are put back securely in their original position after repair. Ensure for safety reasons there is no possibility of secondary problems around the repaired spots. If extended damage is caused due to negligence of repair, the legal responsibility shall be with the repairing company.

4. Caution in removal and making wiring connection to the parts for the automobile.

Disconnect the battery terminal after turning the ignition key off. If wrong wiring connections are made with the battery connected, a short circuit and/or fire may occur. If extensive damage is caused due to negligence of repair, the legal responsibility shall be with the repairing company.

5. Cautions in soldering

Please do not spread liquid flux in soldering.

Please do not wash the soldering point after soldering.

6. Cautions in soldering for chip capacitors

Please solder the chip capacitors after pre-heating for replacement because they are very weak to heat.

Please do not heat the chip capacitors with a soldering iron directly.

7. Cautions in handling for chip parts.

Do not reuse removed chips even when no abnormality is observed in their appearance. Always replace them with new ones. (The chip parts include resistors, capacitors, diodes, transistors, etc).

Please make an operation test after replacement.

8. Cautions in handling flexible PWB

Before working with a soldering iron, make sure that the iron tip temperature is around 270°C. Take care not to apply the iron tip repeatedly (more than three times) to the same patterns. Also take care not to apply the tip with force.

9. Turn the unit OFF during disassembly and parts replacement. Recheck all work before you apply power to the unit.

10. Cautions in checking that the optical pickup lights up.

The laser is focused on the disc reflection surface through the lens of the optical pickup. When checking that the laser optical

diode lights up, keep your eyes more than 30cms away from the lens. Prolonged viewing of the laser within 30cms may damage your eyesight.

11. Cautions in handling the optical pickup

The laser diode of the optical pickup can be damaged by electrostatic charge caused by your clothes and body. Make sure to avoid electrostatic charges on your clothes or body, or discharge static electricity before handling the optical pickup.

11-1. Laser diode

The laser diode terminals are shorted for transportation in order to prevent electrostatic damage. After replacement, open the shorted circuit. When removing the pickup from the mechanism, short the terminals by soldering them to prevent this damage.

11-2. Actuator

The actuator has a powerful magnetic circuit. If a magnetic material is put close to it. Its characteristics will change. Ensure that no foreign substances enter through the ventilation slots in the cover.

11-3. Cleaning the lens

Dust on the optical lens affects performance.

To clean the lens, apply a small amount of isopropyl alcohol to lens paper and wipe the lens gently.

CAUTION

Use of controls, adjustment, or performance of procedures other than those specified herein, may result in hazardous radiation exposure.

The compact disc player should not be adjusted or repaired by anyone except properly qualified service personnel.

THIS DEVICE COMPLIES WITH DHHS RULES 21 CFR SUBCHAPTER J APPLICABLE AT DATE OF MANUFACTURE.

THIS DEVICE COMPLIES WITH PART 15 OF THE FCC RULES. OPERATION IS SUBJECT TO THE FOLLOWING TWO CONDITIONS:
(1) THIS DEVICE MAY NOT CAUSE HARMFUL INTERFERENCE RECEIVED, AND
(2) THIS DEVICE MUST ACCEPT ANY INTERFERENCE RECEIVED, INCLUDING INTERFERENCE THAT MAY CAUSE UNDESIRABLE OPERATION.

THIS PRODUCT INCLUDES TECHNOLOGY OWNED BY MICROSOFT CORPORATION AND CANNOT BE USED OR DISTRIBUTED WITHOUT A LICENSE FROM MSLGP.

PART No.

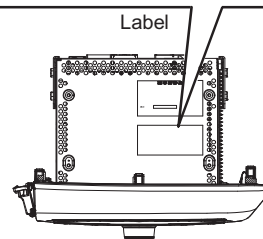

Top view of unit

EXPLODED VIEW / PARTS LIST

The following parts are different from PH-3312C-A.

Other parts are the same as PH-3312C-A.

Escutcheon section

(Please refer to page 12 of service manual for PH-3312C-A)

NO.	PART NO.	DESCRIPTION	Q'TY
1-1	940-8593-14	ES-ASSY(for PH3377CA)	1

Main section

(Please refer to page 13 of service manual for PH-3312C-A)

NO.	PART NO.	DESCRIPTION	Q'TY
13	276-0866-02	SETPLATE(for PH3377CA)	1

EXPLODED VIEW / PARTS LIST

NO.	PART NO.	DESCRIPTION	QTY	NO.	PART NO.	DESCRIPTION	QTY
1	966-1722-21	SH-RACK-ASSY	1	43	621-1749-20	POWER GEAR B	1
2	969-0075-31	PICKUP-ASSY	1	44	621-1750-20	POWER GEAR C	1
3	-----	SENSOR-PWB-ASSY(955010AI)	1	45	621-1751-20	POWER GEAR D	1
4	-----	MAIN-PWB-ASSY(975033BI)	1	46	621-1752-20	DISC STOPPER	1
5	-----	DC-MOTOR(SPINDELE)	1	47	621-1753-20	CLAMPER RING	1
6	-----	DC-MOTOR(SLED)	1	48	621-1754-20	GEAR BASE	1
7	345-5476-20	CUSHION RUBBER	1	49	622-1570-21	DAMPER PIN	3
8	620-1023-23	CLAMPER PLATE	1	50	622-1571-21	ROLLER SHAFT	1
9	620-1026-21	SPRING PLATE	1	51	624-3059-00	LEAD SCREW	1
10	620-1596-23	CLAMPER LINK	1	52	629-0086-20	DAMPER F	2
11	620-1862-20	UPPER CHASSIS	1	53	629-0087-20	DAMPER R	1
12	620-1867-20	DRIVE PLATE	1	54	714-2003-8B	MACHIN SCREW	2
13	620-1752-20	SENSOR ARM	1	55	716-1507-01	SCREW	3
14	620-1753-20	ID-LOCK PLATE	1	56	716-1670-01	SPECIAL SCREW	4
15	620-1894-24	LOWER CHASSIS	1	57	716-1733-01	SCREW	2
16	-----	MOTOR GEAR(SLED)	1	58	716-3469-01	SPECIAL SCREW	2
17	621-0608-21	SECOND GEAR	1	59	716-3473-01	SPECIAL SCREW	1
18	621-0609-21	BASE GEAR	1	60	716-3551-00	SPECIAL SCREW	2
19	621-0610-21	IDLE GEAR A	1	61	750-6797-20	ROLLER SPRING L	1
20	621-0611-21	IDLE GEAR B	1	62	750-6798-20	ROLLER SPRING R	1
21	621-0612-22	ROLLER GEAR A	1	63	750-7865-20	SHIFT SPRING	1
22	621-0620-20	THREAD GEAR A	1	64	750-7866-20	RACK SPRING	1
23	621-0621-20	THREAD GEAR B	1	65	750-7867-20	CLAMPER SPRING	1
24	621-0623-24	LS-HOLDER	1	66	750-7868-20	ID-LOCK SPRING	1
25	621-0624-22	GUIDE RAIL	1	67	750-7869-20	SENSOR SPRING	1
26	-----	TURN TABLE(SPINDELE)	1	68	750-7870-20	DR-SPRING F	2
27	621-0711-21	LOADING ROLLER	2	69	750-7871-20	DR-SPRING RA	1
28	621-0718-21	ROLLER GUIDE	1	70	750-7872-20	DR-SPRING RB	1
29	621-0719-20	ROLLER GEAR	1	71	750-7873-20	DR-SPRING C	1
30	621-0720-20	ROLLER GEAR C	1	72	780-2025-00	SCREW	3
31	621-0721-20	ROLLER GEAR D	1	73	781-1730-00	SCREW	1
32	621-0728-20	STOPPER LINK	1	74	803-4906-60	VINYL-COAT-WIRE	1
33	621-1719-21	IDLE CASE	1	75	816-2624-55	FLAT WIRE	1
34	621-1726-21	ROLLER SLEEVE	2	76	816-2590-00	SPECIAL LEAD	1
35	621-1729-21	SH-BASE	1	77	816-2591-00	SPECIAL LEAD	1
36	621-1742-20	UPPER GUIDE	1	78	816-2592-00	SPECIAL LEAD	1
37	621-1743-20	SHIFT LEVER	1	79	816-2593-00	SPECIAL LEAD	1
38	621-1744-20	RACK	1	80	716-3635-00	SPECIAL SCREW	1
39	621-1745-20	LOCK ARM L	1	81	293-8575-00	MECH LABEL	1
40	621-1746-20	LOCK ARM R	1	82	SMA-183-200	SLED MOTOR ASSY	1
41	621-1747-20	GEAR COVER	1	83	SMA-200-100	SPINDLE MOTOR ASSY	1
42	621-1748-20	POWER GEAR A	1				

ELECTRICAL PARTS LIST

SENS PWB(B1) section

REF No.	PART No.	DESCRIPTION	REF No.	PART No.	DESCRIPTION	REF No.	PART No.	DESCRIPTION
D1	001-7058-90	DIODE	S2	013-7413-50	DETECTOR SWITCH(SPVG12)	J1	074-2215-60	10P
D2	001-7058-90	DIODE	Q1	060-4015-91	PHOTO-TR	PWB	039-2675-20	PWB (WITHOUT COMPONENT)
S1	013-7414-50	DETECTOR SWITCH(SPVG22)	Q2	060-4015-91	PHOTO-TR			

MAIN PWB(B2) section

REF No.	PART No.	DESCRIPTION	REF No.	PART No.	DESCRIPTION	REF No.	PART No.	DESCRIPTION
C3	168-1052-78	16V 1uF K	C47	166-1011-50	100pF CH	R13	033-3341-15	1/16W 330k ohm J
C6	168-1052-78	16V 1uF K	C48	165-4763-15	6.3V 47uF	R15	033-4731-15	1/16W 47k ohm J
C7	042-0560-85	6.3V 100uF	C49	168-1042-78	16V 0.1uF K	R16	033-3331-15	1/16W 33k ohm J
C8	168-1052-78	16V 1uF K	C50	045-1201-50	12pFJ CH	R17	119-0000-05	1/10W 0 ohm JW
C10	046-1042-78	16V 0.1uF	C51	045-1201-50	12pFJ CH	R18	033-1051-15	1/16W 1M ohm J
C11	168-1042-78	16V 0.1uF K	C71	166-6801-50	68pF CH	R19	033-2221-15	1/16W 2.2k ohm J
C12	166-6801-50	68pF CH	C72	166-6801-50	68pF CH	R20	033-1011-15	1/16W 100 ohm J
C14	046-4722-58	4700pF K B	C73	166-6801-50	68pF CH	R22	119-0000-05	1/10W 0 ohm JW
C17	165-1073-35	16V 100uF	C74	166-6801-50	68pF CH	R24	119-0000-05	1/10W 0 ohm JW
C18	168-1042-78	16V 0.1uF K	C75	166-6801-50	68pF CH	R27	033-0000-05	1/16W 0 ohm
C19	046-1042-78	16V 0.1uF	C76	166-6801-50	68pF CH	R28	033-0000-05	1/16W 0 ohm
C20	046-1532-78	0.015uF K B	C77	166-6801-50	68pF CH	R29	033-0000-05	1/16W 0 ohm
C21	046-1042-78	16V 0.1uF	C78	166-6801-50	68pF CH	R30	033-0000-05	1/16W 0 ohm
C22	168-1042-78	16V 0.1uF K	ET1	073-0792-90	TERMINAL	R31	033-0000-05	1/16W 0 ohm
C23	046-1522-58	1500pF K B	ET2	073-0792-90	TERMINAL	R32	033-0000-05	1/16W 0 ohm
C24	046-1042-78	16V 0.1uF	IC1	051-6751-00	TC94A93MFG-201	R33	033-0000-05	1/16W 0 ohm
C25	046-2222-58	2200pF K B	IC2	051-6101-90	BD8226EFV	R34	033-0000-05	1/16W 0 ohm
C27	168-1042-78	16V 0.1uF K	J1	074-2215-65	15P	R35	033-0000-05	1/16W 0 ohm
C28	043-0559-90	6.3V 22uF	J2	074-2215-60	10P	R36	033-0000-05	1/16W 0 ohm
C29	046-1032-78	16V 0.01uF	J3	074-3032-40	40P	R37	033-0000-05	1/16W 0 ohm
C30	046-4712-58	470pF K B	L1	010-3105-69	80 ohm/100MHz	R38	033-0000-05	1/16W 0 ohm
C31	046-4712-58	470pF K B	L2	010-3105-69	80 ohm/100MHz	R39	033-0000-05	1/16W 0 ohm
C32	046-3332-78	0.033uF K B	L3	010-3105-69	80 ohm/100MHz	R40	033-1041-15	1/16W 100k ohm J
C33	168-1532-55	0.015uF K	L4	010-3105-69	80 ohm/100MHz	R41	033-1011-15	1/16W 100 ohm J
C34	168-1042-78	16V 0.1uF K	Q1	190-2060-00	2SA2060	R42	033-1011-15	1/16W 100 ohm J
C35	166-6801-50	68pF CH	R1	033-2211-15	1/16W 220 ohm J	R44	033-0000-05	1/16W 0 ohm
C36	046-6822-58	6800pF K B	R2	117-6811-15	1/10W 680 ohm	R45	033-4721-15	1/16W 4.7k ohm J
C37	045-4701-50	47pF CH	R3	117-1001-15	1/8W 10 ohm	R46	033-4721-15	1/16W 4.7k ohm J
C38	168-1042-78	16V 0.1uF K	R4	033-1831-15	1/16W 18k ohm J	R47	033-4721-15	1/16W 4.7k ohm J
C39	046-1042-78	16V 0.1uF	R5	033-1231-15	1/16W 12k ohm J	R48	033-4721-15	1/16W 4.7k ohm J
C40	168-1042-78	16V 0.1uF K	R6	033-1541-15	1/16W 150k ohm J	VR1	001-9210-50	AVR- M1608C270MTAAD
C41	046-5622-58	5600pF K B	R7	033-1031-15	1/16W 10k ohm J	X1	061-3572-90	16.92MHZ
C42	168-1042-78	16V 0.1uF K	R8	033-0000-05	1/16W 0 ohm	PWB	039-3723-00	PWB(WITHOUT COMPONENTS)
C43	046-4732-78	16V 0.047uF	R9	033-2211-15	1/16W 220 ohm J			
C44	046-4732-78	16V 0.047uF	R10	033-0000-05	1/16W 0 ohm			
C45	168-1042-78	16V 0.1uF K	R11	033-2231-15	1/16W 22k ohm J			
C46	043-0570-90	16V 2.2uF K	R12	033-4731-15	1/16W 47k ohm J			