

EXPLODED VIEW / PARTS LIST

Panel section

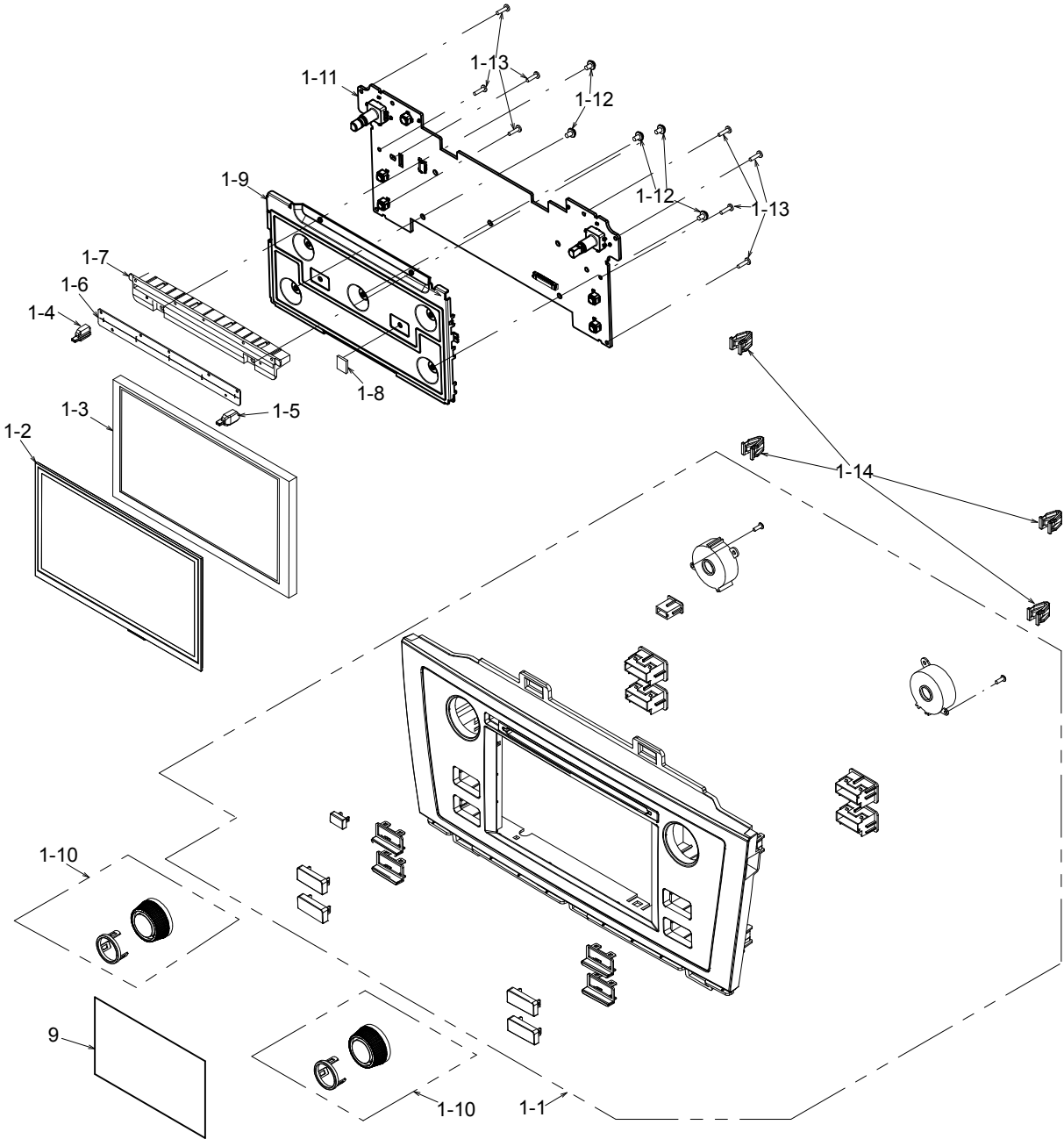

Main section

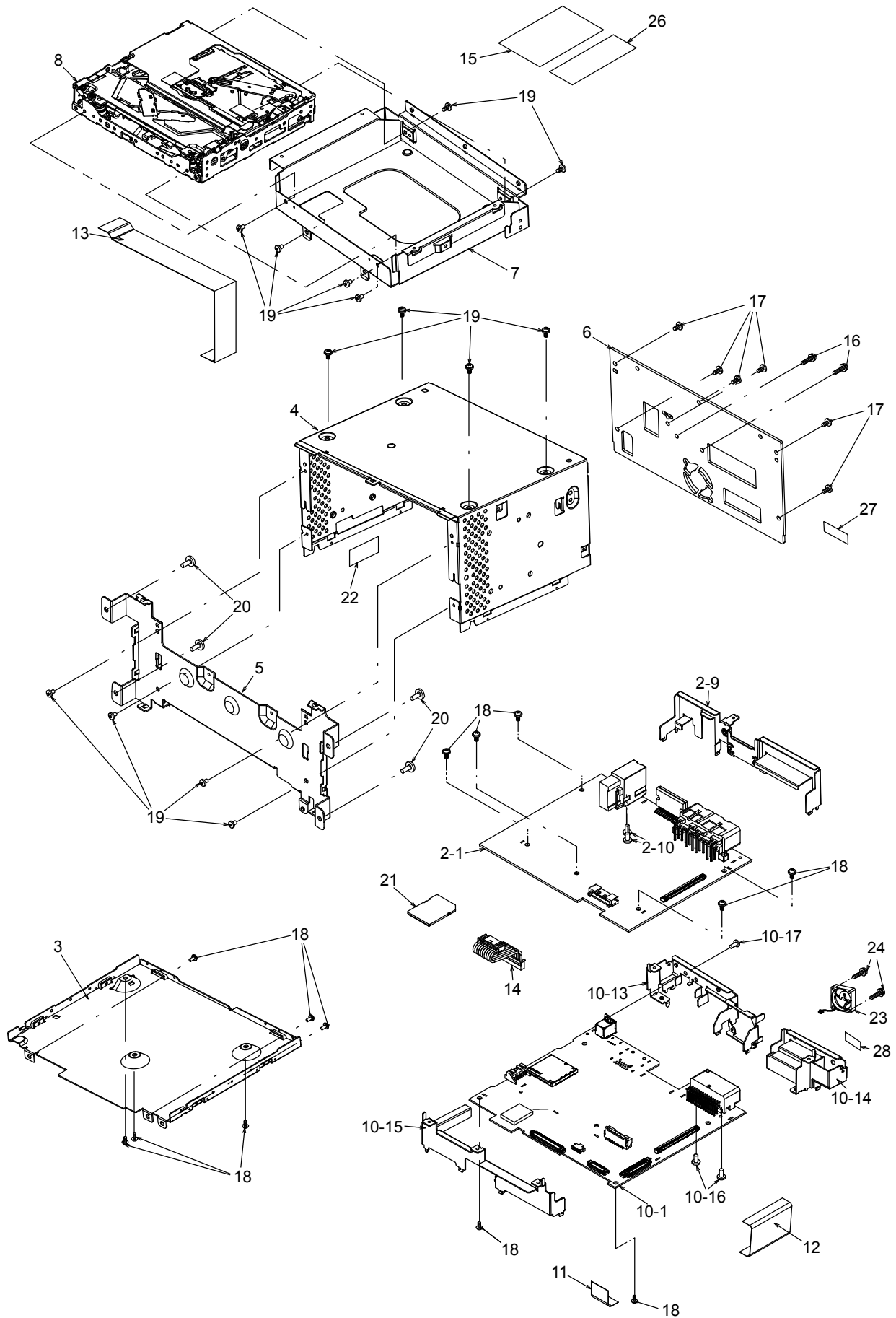

NO.	PART NO.	DESCRIPTION	Q'TY
1	-----	-	-
1-1	940-8728-15	ESCUTCHEON-ASSY (PF-3636I-A)	1
	940-8728-85	ESCUTCHEON-ASSY (PF-3689I-A)	1
1-2	013-9745-00	TOUCH PANEL	1
1-3	379-0491-02	TFT	1
1-4	335-9524-01	GUIDE ILLUMI(L)	1
1-5	335-9525-01	GUIDE ILLUMI(R)	1
1-6	346-0314-01	LEATHER SHEET	1
1-7	335-9523-01	DISC GUIDE	1
1-8	331-3038-50	EARTH PLATE	1
1-9	331-5532-03	LCD HOLDER	1
1-10	947-0834-01	KNOB-ASSY	2
1-11	-----	SW-PWB(428200-039)	1
1-12	716-0878-50	SPECIAL SCREW	5
1-13	716-0778-52	SPECIAL SCREW	8
1-14	335-8017-00	GARNISH CLIP	4
2	-----	-	-
2-1	-----	MAIN-PWB(425100-039)	1
2-2	-----	-	-
2-3	-----	-	-
2-4	-----	-	-
2-5	-----	-	-
2-6	-----	-	-
2-7	-----	-	-
2-8	-----	-	-
2-9	331-5535-02	BRKT-C	1
2-10	778-3006-00	TAP-SCREW	2
3	311-2084-11	LOWER CASE	1
4	310-2026-12	UPPER CASE	1
5	309-1976-02	FRONT PLATE	1
6	313-2194-12	HEAT SINK	1
7	331-5531-01	MECH-BRKT	1
8	929-5400-80	CD-MECH-MODULE	1
9	347-9449-02	PROTECTOR	1
10	-----	-	-
10-1	-----	NAVI-PWB(426900-039)	1
10-2	-----	-	-

NO.	PART NO.	DESCRIPTION	Q'TY
10-3	-----	-	-
10-4	-----	-	-
10-5	-----	-	-
10-6	-----	-	-
10-7	-----	-	-
10-8	-----	-	-
10-9	-----	-	-
10-10	-----	-	-
10-11	-----	-	-
10-12	-----	-	-
10-13	331-5533-03	BRKT-L	1
10-14	331-5534-01	BRKT-R	1
10-15	331-5586-01	BRKT-F	1
10-16	778-3006-00	TAP-SCREW	2
10-17	714-2606-8B	MACHINE SCREW	1
11	816-3135-55	FLAT WIRE	1
12	816-3105-55	FLAT WIRE	1
13	816-3167-57	FLAT WIRE	1
14	854-4667-52	EXTENSION LEAD	1
15	-----	SETPLATE (113636-276) (PF-3636I-A) (113638-276) (PF-3689I-A)	1
16	714-2614-8B	MACHINE SCREW	2
17	714-2606-8B	MACHINE SCREW	6
18	716-0878-50	SPECIAL SCREW	13
19	714-2604-8B	MACHINE SCREW	14
20	716-1553-50	SPECIAL SCREW	4
21	-----	SD CARD(002310-065)	1
22	347-9373-00	PAPER PART	1
23	020-3066-00	DC-MOTOR	1
24	732-2614-1B	SEMS SCREW	2
25	-----	-	-
26	-----	LABEL(075400-290)	1
27	290-0548-61	LABEL (PF-3636I-A)	1
	290-0548-60	LABEL (PF-3689I-A)	1
28	347-9381-00	PROTECT-SHEET	1

EXPLODED VIEW / PARTS LIST

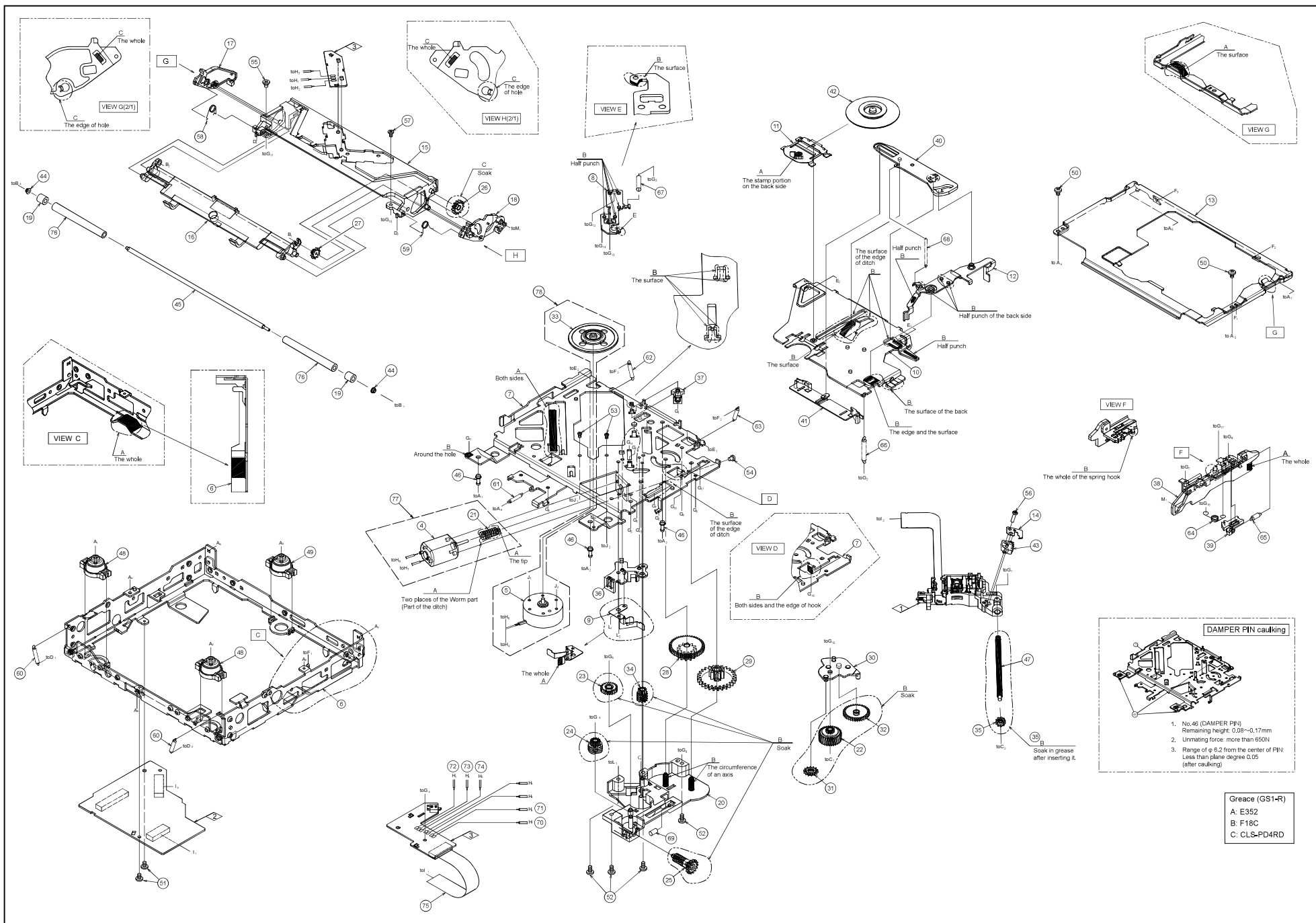

DAMPER PIN caulking

- No.46 (DAMPER PIN)
Remaining height: 0.08~0.17mm
- Unmating force: more than 650N
- Range of ϕ 6.2 from the center of PIN:
Less than plane degree 0.05 (after caulking)

Grease (GS1-R)
 A: E352
 B: F18C
 C: CLS-PD4RD

NO.	PART NO.	DESCRIPTION	QTY	NO.	PART NO.	DESCRIPTION	QTY
1	969-0085-30	PICKUP-ASSY	1	40	621-1870-21	STOPPER LINK	1
2	-----	MAIN-PWB-ASSY	1	41	621-1871-22	DISC STOPPER	1
3	-----	SENSOR-PWB-ASSY	1	42	621-1872-21	CLAMPER RING	1
4	-----	DC-MOTOR(PWR)(154200-020)	1	43	621-1902-20	LS-RACK	1
5	-----	DC-MOTOR(SPN)(154100-020)	1	44	621-1726-21	ROLLER SLEEVE	2
6	620-1952-20	LOWER CHASSIS	1	45	622-1885-20	ROLLER SHAFT	1
7	620-1911-20	DRIVE PLATE	1	46	622-1886-20	DAMPER PIN	3
8	620-1912-21	ID-LOCK PLATE	1	47	624-3062-20	LEAD SCREW	1
9	620-1943-21	SPRING PLATE	1	48	629-0137-20	DAMPER F	2
10	620-1914-21	CLAMPER ARM	1	49	629-0141-20	DAMPER R	1
11	620-1953-20	CLAMPER PLATE	1	50	714-2003-8B	MACHIN SCREW	2
12	620-1916-22	SENSOR ARM	1	51	716-3718-00	SPECIAL SCREW	2
13	620-1944-21	UPPER CHASSIS	1	52	716-3719-00	SPECIAL SCREW	4
14	620-1947-21	LS-RACK PLATE	1	53	716-3720-00	SPECIAL SCREW	2
15	621-1877-20	UPPER GUIDE	1	54	716-3721-00	SPECIAL SCREW	1
16	621-1846-22	ROLLER GUIDE	1	55	716-3722-00	SPECIAL SCREW	1
17	621-1894-20	LOCK ARM L	1	56	716-3723-02	SPECIAL-SCREW	1
18	621-1895-20	LOCK ARM R	1	57	716-3724-00	SPECIAL SCREW	1
19	621-1905-20	LOADING ROLLER A	2	58	750-7947-20	ROLLER SPRING L	1
20	621-1896-21	GEAR BOX	1	59	750-7948-20	ROLLER SPRING R	1
21	-----	MOTOR GEAR(185121-621)	1	60	750-7926-20	DR-SPRING F	2
22	621-1852-20	SECOND GEAR	1	61	750-7927-20	DR-SPRING C	1
23	621-1853-20	ROLLER GEAR A	1	62	750-7928-20	DR-SPRING RA	1
24	621-1907-20	ROLLER GEAR B	1	63	750-7929-20	DR-SPRING RB	1
25	621-1908-20	ROLLER GEAR C	1	64	750-7930-20	SHIFT SPRING	1
26	621-1856-20	ROLLER GEAR D	1	65	750-7931-20	RACK SPRING	1
27	621-1857-21	ROLLER GEAR E	1	66	750-7932-20	CLAMPER SPRING	1
28	621-1897-20	POWER GEAR A	1	67	750-7933-20	ID-LOCK SPRING	1
29	621-1898-20	POWER GEAR B	1	68	750-7869-20	SENSOR SPRING	1
30	621-1892-20	IDLE CASE	1	69	750-7942-21	GEAR-BOX-SPRING	1
31	621-1861-20	IDLE GEAR A	1	70	803-4906-60	VINYL-COAT-WIRE(ORG)	1
32	621-1862-20	IDLE GEAR B	1	71	816-2590-00	SPECIAL LEAD(GRN)	1
33	-----	TURN TABLE(186320-621)	1	72	816-2591-00	SPECIAL LEAD(YEL)	1
34	621-1864-20	THREAD GEAR A	1	73	816-2592-00	SPECIAL LEAD(PUR)	1
35	621-1865-20	THREAD GEAR B	1	74	816-2593-00	SPECIAL LEAD(BLU)	1
36	621-1866-20	LS-HOLDER A	1	75	816-4070-50	FLAT WIRE	1
37	621-1867-20	LS-HOLDER B	1	76	621-1906-20	LADING ROLLER B	2
38	621-1893-23	SHIFT LEVER	1	77	HBS-673-100	POWER-MOTOR-ASSY	1
39	621-1869-21	RACK	1	78	HBS-669-100	SPINDLE-MOOR-ASSY	1

ELECTRICAL PARTS LIST

SENSOR PWB(B1) section

REF NO.	PART NO.	DESCRIPTION	REF NO.	PART NO.	DESCRIPTION	REF NO.	PART NO.	DESCRIPTION
D1	001-7138-91	SML-S13RT T86	Q1	060-4025-90	SML-H10TBT86	PWB	039-3732-20	PWB(WITHOUT COMPONENTS)
D2	001-7138-91	SML-S13RT T86	Q2	060-4025-90	SML-H10TBT86			
J1	074-2504-10	OUTLET SOCKET	S2	013-7423-50	SPVT240101			

MAIN PWB(B2) section

REF NO.	PART NO.	DESCRIPTION	REF NO.	PART NO.	DESCRIPTION	REF NO.	PART NO.	DESCRIPTION
C2	168-1052-78	16V 1uF K	C46	043-0570-90	16V 2.2uF K	R19	033-0000-05	1/16W 0 ohm
C4	046-1042-78	0.1uF K B	C47	046-1042-78	0.1uF K B	R20	033-3331-15	1/16W 33k ohm J
C5	168-1052-78	16V 1uF K	C48	046-1042-78	0.1uF K B	R21	033-4731-15	1/16W 47k ohm J
C7	042-0560-85	6.3V 100uF	C50	045-1201-50	12pFJ CH	R22	033-3301-15	1/16W 33 ohm J
C10	168-1052-78	16V 1uF K	C51	045-1501-50	15pFJ CH	R27	033-1051-15	1/16W 1M ohm J
C11	046-1042-78	0.1uF K B	C57	046-1042-78	0.1uF K B	R28	033-2221-15	1/16W 2.2k ohm J
C12	165-1073-35	16V 100uF	C59	165-4763-15	6.3V 47uF	R30	033-2211-15	1/16W 220 ohm J
C14	046-1042-78	0.1uF K B	C66	046-1042-78	0.1uF K B	R32	033-2211-15	1/16W 220 ohm J
C15	046-1042-78	0.1uF K B	C67	042-0560-85	6.3V 100uF	R38	033-4721-15	1/16W 4.7k ohm J
C17	046-4722-58	4700pF K B	C68	046-1042-78	0.1uF K B	R40	119-0000-05	1/10W 0 ohm JW
C18	046-1042-78	0.1uF K B	C79	043-4306-90	1uF	R41	119-0000-05	1/10W 0 ohm JW
C19	046-1042-78	0.1uF K B	C80	045-1007-50	10 +/-0.5pF CH	R42	119-0000-05	1/10W 0 ohm JW
C20	168-1052-78	16V 1uF K	IC1	051-6101-70	BD8266EFV-ME2	R66	033-2731-15	1/16W 27k ohm J
C21	046-1522-58	1500pF K B	IC2	051-6751-00	TC94A93MFG-201	R69	033-2211-15	1/16W 220 ohm J
C22	046-1042-78	0.1uF K B	J1	074-2215-65	15P	R70	033-2211-15	1/16W 220 ohm J
C23	046-1532-78	0.015uF K B	J2	074-2504-10	OUTLET SOCKET	R71	033-2211-15	1/16W 220 ohm J
C25	046-2222-58	2200pF K B	J4	074-2248-40	SOCKET(40P)	R80	033-0000-05	1/16W 0 ohm
C26	046-4712-58	470pF K B	Q1	190-1365-50	2SA1365 AF,AG	R81	033-1041-15	1/16W 100k ohm J
C27	046-1032-78	0.01uF K B	R1	033-2211-15	1/16W 220 ohm J	R92	033-2211-15	1/16W 220 ohm J
C28	046-3332-78	0.033uF K B	R2	033-4721-15	1/16W 4.7k ohm J	R93	033-3301-15	1/16W 33 ohm J
C29	046-4712-58	470pF K B	R3	033-4721-15	1/16W 4.7k ohm J	R94	033-1041-15	1/16W 100k ohm J
C30	168-1532-55	0.015uF K	R4	117-8211-15	1/8W 820 ohm	RN1	050-0140-67	1/32W 220 ohm x4J
C31	046-1042-78	0.1uF K B	R5	033-1831-15	1/16W 18k ohm J	RN2	050-0140-67	1/32W 220 ohm x4J
C32	045-4701-50	47pF CH	R6	033-1231-15	1/16W 12k ohm J	RN3	050-0140-57	1/32W 10k ohm x4J
C33	046-3322-58	3300pF K B	R7	116-1001-15	1/4W 10 ohm	RN4	050-0140-59	1/32W 33 ohm x4J
C34	046-1042-78	0.1uF K B	R8	033-1541-15	1/16W 150k ohm J	RN5	050-0140-64	1/32W 100k ohm x4J
C35	045-6801-50	68pFJ CH	R9	033-1031-15	1/16W 10k ohm J	VR4	001-9210-50	AVR-M1608C270 MTAAD
C36	046-1042-78	0.1uF K B	R10	033-1041-15	1/16W 100k ohm J	X1	061-3586-90	DSX321(G)F 16.920MHz
C37	046-5622-58	5600pF K B	R11	033-1041-15	1/16W 100k ohm J	PWB	039-4220-20	PWB(WITHOUT COMPONENTS)
C38	046-4732-78	0.047uF K B	R12	033-1031-15	1/16W 10k ohm J			
C39	046-4732-78	0.047uF K B	R15	033-2211-15	1/16W 220 ohm J			
C40	046-1042-78	0.1uF K B	R16	033-2231-15	1/16W 22k ohm J			
C41	046-1042-78	0.1uF K B	R17	033-4731-15	1/16W 47k ohm J			
C45	046-1042-78	0.1uF K B	R18	033-3341-15	1/16W 330k ohm J			