

Service Manual

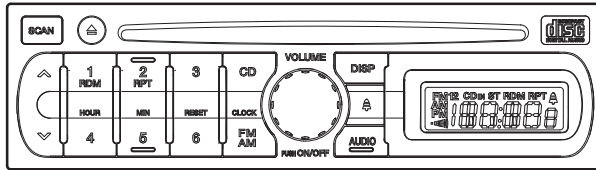

ISUZU Automobile Genuine
 AM/FM Stereo CD Deck

Model **PI-2987T-A**
 (Genuine No.8-98065-4740)

ORIGINAL SERVICE MANUAL

This additional service manual is designed to be used together with Original model.

Original model	Manual No.
PI-2987B-A	298-6449-00

DIFFERENCE FROM ORIGINAL MODEL

1. Additional ILL Reversing Circuit
2. BLOCK DIAGRAM
3. EXPLODE VIEW / PARTS LIST
4. ELECTRICAL PARTS LIST
5. PRINTED WIRING BOARD
6. CIRCUIT DIAGRAM

NOTE

- * We cannot supply PWB with component parts in principle. When a circuit on PWB has failure, please repair it by component parts base. Parts which are not mentioned in service manual are not supplied.
- * Specifications and design are subject to change without notice for further improvement.

COMPONENTS

PI-2987T-A		
Main unit	-----	1

CAUTIONS

Use of controls, adjustment, or performance of procedures other than those specified herein, may result in hazardous radiation exposure.

The compact disc player should not be adjusted or repaired by anyone except properly qualified service personnel.

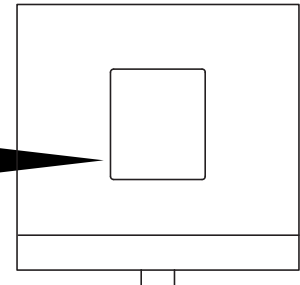
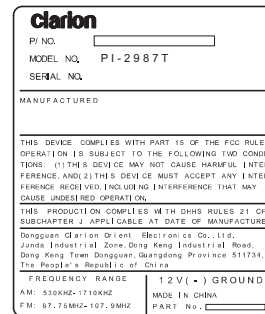

To engineers in charge of repair or inspection of our products.

Before repair or inspection, make sure to follow the instructions so that customers and Engineers in charge of repair or inspection can avoid suffering any risk or injury.

1. Use specified parts.
 The system uses parts with special safety features against fire and voltage. Use only parts with equivalent characteristics when replacing them.
 The use of unspecified parts shall be regarded as remodeling for which we shall not be liable. The onus of product liability (PL) shall not be our responsibility in cases where an accident or failure is as a result of unspecified parts being used.
2. Place the parts and wiring back in their original positions after replacement or re-wiring.

DIFFERENCE ELECTRICAL PARTS LIST

Main PWB section(B1)

(Refer to the original service manual, page 7 to 8.)

The following parts are additional parts.

REF No.	PART No.	DESCRIPTION
C229	188-4756-58	35V 4.7uF
C233	172-1041-15	0.1uF
C235	163-4743-65	0.47uF

REF No.	PART No.	DESCRIPTION
Q222	193-1306-00	2SD1306
R245	119-4721-15	1/10W 4.7k ohm
R246	116-1221-15	1/4W 1.2k ohm

REF No.	PART No.	DESCRIPTION
R247	116-1831-15	1/4W 18k ohm
R248	116-1221-15	1/4W 1.2k ohm

The following part is removal part.

REF No.	PART No.	DESCRIPTION
R269	116-0000-05	1/4W 0 ohm

The following parts are difference parts.

REF No.	PART No.	DESCRIPTION
C239	111-4721-98	1/4W 4.7k ohm
C243	163-1053-65	50V 1uF

CIRCUIT DIAGRAM

Main PWB(B1) section 3/3

(Refer to page 11 of the original service manual.)

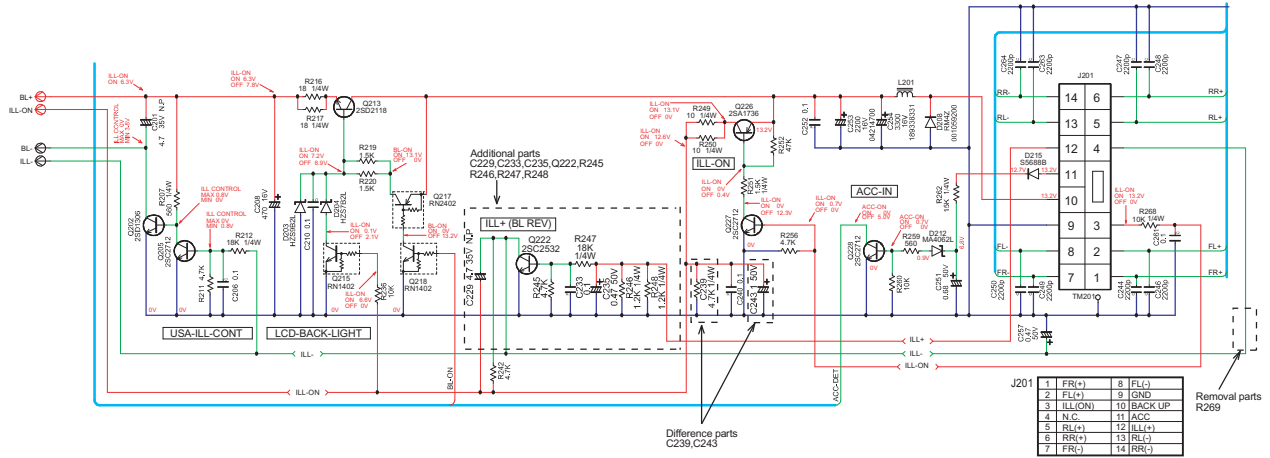

PRINTED WIRING BOARD

Main PWB(B1) section 1/2

(Refer to page 12 of the original service manual.)

