

# EXPLODED VIEW/PARTS LIST

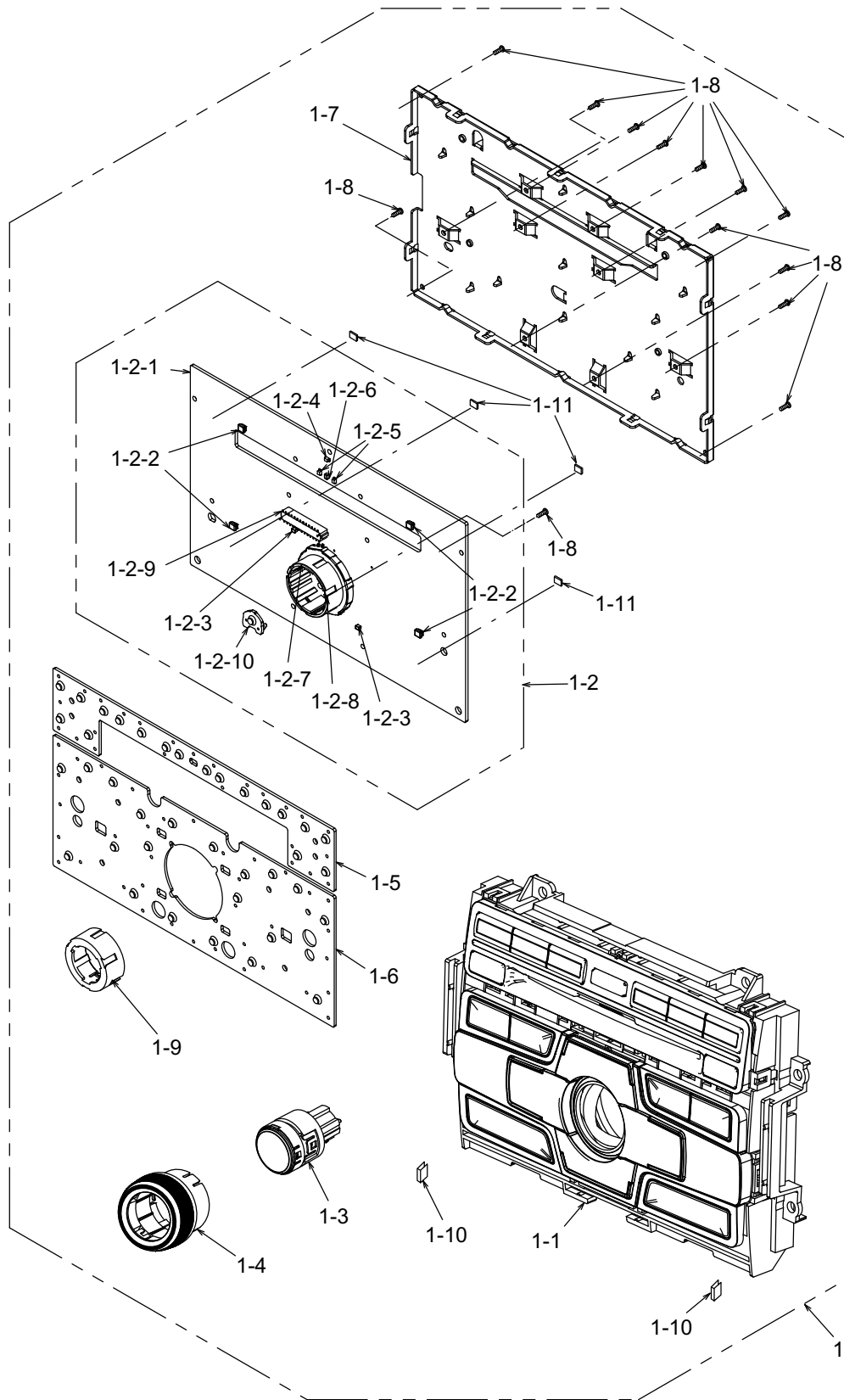

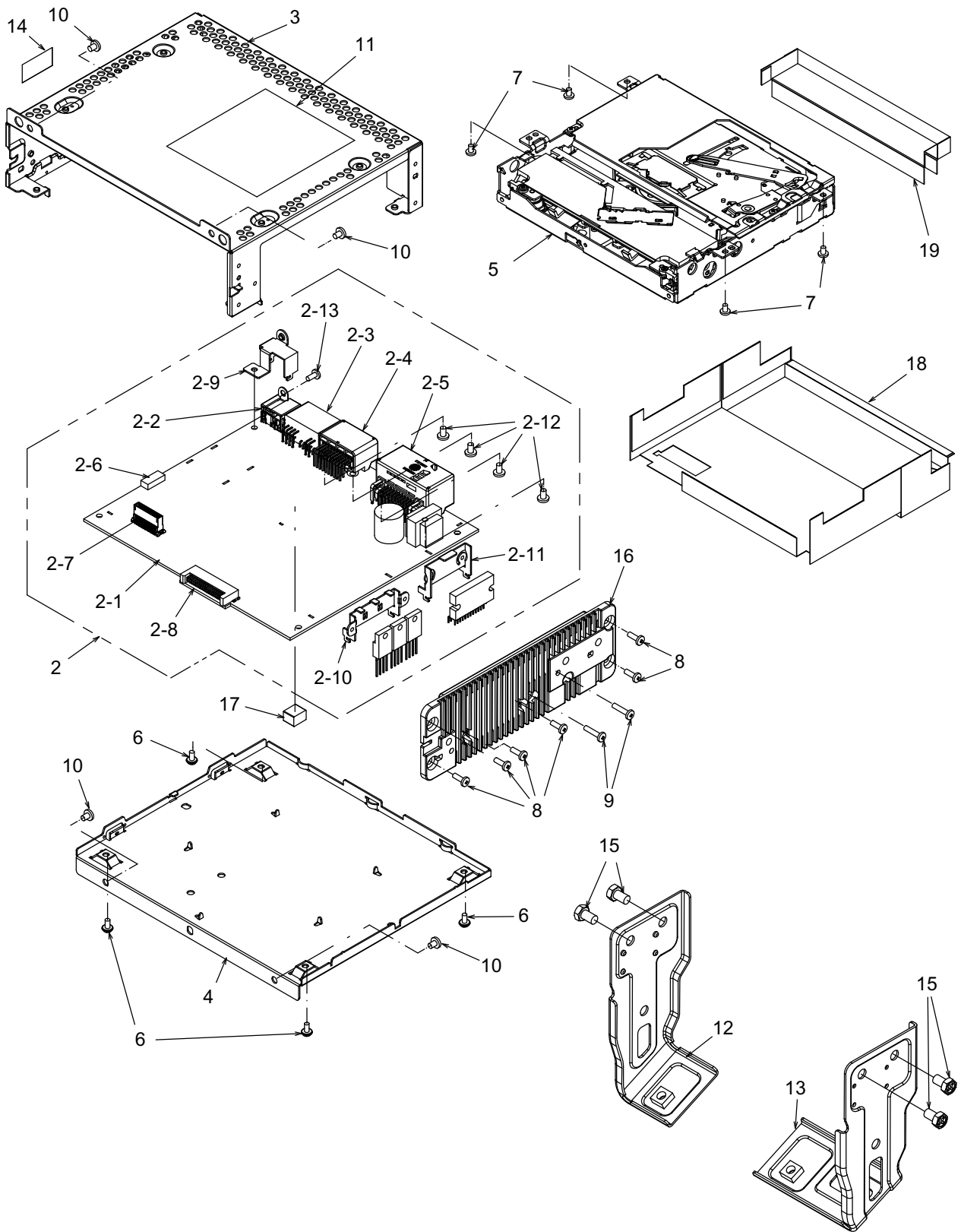

NO.	PART NO.	DESCRIPTION	Q'TY	NO.	PART NO.	DESCRIPTION	Q'TY
1	-----	PANEL-ASSY (3588A0-45)	1	2-5	074-4026-24	OUTLET SOCKET(24pin)	1
1-1	940-8700-34	ESCUTCHEON-ASSY	1	2-6	076-0478-58	PLUG(8pin)	1
1-2	-----	SW-PWB-ASSY (3312A7-77)	1	2-7	076-3028-40	PLUG(40pin)	1
1-2-1	-----	SWITCH PWB(371801-039)	1	2-8	076-3011-76	PLUG(26pin)	1
1-2-2	001-7110-94	DIODE	4	2-9	331-5070-00	ANT-HOLDER	1
1-2-3	001-7134-55	DIODE	2	2-10	331-5071-00	TR-HOLDER	1
1-2-4	001-7115-92	DIODE	1	2-11	331-3459-00	IC HOLDER	1
1-2-5	001-7142-90	DIODE	2	2-12	778-3005-00	TAP SCREW	4
1-2-6	001-7134-61	DIODE	1	2-13	714-2606-8B	MACHINE SCREW	1
1-2-7	001-7134-62	DIODE	1	3	310-1955-01	UPPER CASE	1
1-2-8	016-7006-02	VR W/SHAFT	1	4	311-2024-00	LOWER CASE	1
1-2-9	074-3014-76	OUTLET SOCKET(26pin)	1	5	929-5033-80	CD-MECH-MODULE	1
1-2-10	345-6498-00	RUBBER SWITCH(C)	1	6	716-0878-50	SPECIAL SCREW	4
1-3	948-4001-01	BUTTON ASSY	1	7	714-2604-8B	MACHINE SCREW	4
1-4	947-0820-02	KNOB ASSY	1	8	714-2608-8B	MACHINE SCREW	6
1-5	345-6496-00	RUBBER SWITCH(A)	1	9	780-2612-01	SPECIAL-M-SCREW	2
1-6	345-6497-01	RUBBER SWITCH(B)	1	10	714-3004-8B	MACHINE SCREW	4
1-7	331-5076-00	ES PLATE ASSY	1	11	276-0928-29	SETPLATE	1
1-8	716-0778-52	SPECIAL SCREW	13	12	300-8409-01	MTG-BRKT(L)	1
1-9	335-9002-00	SPACER	1	13	300-8410-01	MTG-BRKT(R)	1
1-10	347-8895-00	CUSHION SHEET	2	14	347-8899-00	SHADE	1
1-11	347-9093-00	SPACER	4	15	782-5008-01	SPECIAL-H-BOLT	4
2	-----	MAIN-PWB-ASSY (3312A7-75)	1	16	313-2125-00	HEAT SINK	1
2-1	-----	MAIN PWB(371700-039)	1	17	345-6341-00	GASKET	1
2-2	092-2238-00	ANT-RECEPT(CE2)	1	18	347-8981-00	MECH CVR	1
2-3	074-1168-14	OUTLET SOCKET(14pin)	1	19	347-9021-01	MECH CVR	1
2-4	074-4017-20	OUTLET SOCKET(20pin)	1				

## EXPLODED VIEW / PARTS LIST

NO.	PART NO.	DESCRIPTION	QTY	NO.	PART NO.	DESCRIPTION	QTY
1	966-1722-21	SH-RACK-ASSY	1	43	621-1749-20	POWER GEAR B	1
2	969-0075-31	PICKUP-ASSY	1	44	621-1750-20	POWER GEAR C	1
3	-----	SENSOR-PWB-ASSY(955010AI)	1	45	621-1751-20	POWER GEAR D	1
4	-----	MAIN-PWB-ASSY(975033BI)	1	46	621-1752-20	DISC STOPPER	1
5	-----	DC-MOTOR(SPINDELE)	1	47	621-1753-20	CLAMPER RING	1
6	-----	DC-MOTOR(SLED)	1	48	621-1754-20	GEAR BASE	1
7	345-5476-20	CUSHION RUBBER	1	49	622-1570-21	DAMPER PIN	3
8	620-1023-23	CLAMPER PLATE	1	50	622-1571-21	ROLLER SHAFT	1
9	620-1026-21	SPRING PLATE	1	51	624-3059-00	LEAD SCREW	1
10	620-1596-23	CLAMPER LINK	1	52	629-0086-20	DAMPER F	2
11	620-1862-20	UPPER CHASSIS	1	53	629-0087-20	DAMPER R	1
12	620-1867-20	DRIVE PLATE	1	54	714-2003-8B	MACHIN SCREW	2
13	620-1752-20	SENSOR ARM	1	55	716-1507-01	SCREW	3
14	620-1753-20	ID-LOCK PLATE	1	56	716-1670-01	SPECIAL SCREW	4
15	620-1894-24	LOWER CHASSIS	1	57	716-1733-01	SCREW	2
16	-----	MOTOR GEAR(SLED)	1	58	716-3469-01	SPECIAL SCREW	2
17	621-0608-21	SECOND GEAR	1	59	716-3473-01	SPECIAL SCREW	1
18	621-0609-21	BASE GEAR	1	60	716-3551-00	SPECIAL SCREW	2
19	621-0610-21	IDLE GEAR A	1	61	750-6797-20	ROLLER SPRING L	1
20	621-0611-21	IDLE GEAR B	1	62	750-6798-20	ROLLER SPRING R	1
21	621-0612-22	ROLLER GEAR A	1	63	750-7865-20	SHIFT SPRING	1
22	621-0620-20	THREAD GEAR A	1	64	750-7866-20	RACK SPRING	1
23	621-0621-20	THREAD GEAR B	1	65	750-7867-20	CLAMPER SPRING	1
24	621-0623-24	LS-HOLDER	1	66	750-7868-20	ID-LOCK SPRING	1
25	621-0624-22	GUIDE RAIL	1	67	750-7869-20	SENSOR SPRING	1
26	-----	TURN TABLE(SPINDELE)	1	68	750-7870-20	DR-SPRING F	2
27	621-0711-21	LOADING ROLLER	2	69	750-7871-20	DR-SPRING RA	1
28	621-0718-21	ROLLER GUIDE	1	70	750-7872-20	DR-SPRING RB	1
29	621-0719-20	ROLLER GEAR	1	71	750-7873-20	DR-SPRING C	1
30	621-0720-20	ROLLER GEAR C	1	72	780-2025-00	SCREW	3
31	621-0721-20	ROLLER GEAR D	1	73	781-1730-00	SCREW	1
32	621-0728-20	STOPPER LINK	1	74	803-4906-60	VINYL-COAT-WIRE	1
33	621-1719-21	IDLE CASE	1	75	816-2624-55	FLAT WIRE	1
34	621-1726-21	ROLLER SLEEVE	2	76	816-2590-00	SPECIAL LEAD	1
35	621-1729-21	SH-BASE	1	77	816-2591-00	SPECIAL LEAD	1
36	621-1742-20	UPPER GUIDE	1	78	816-2592-00	SPECIAL LEAD	1
37	621-1743-20	SHIFT LEVER	1	79	816-2593-00	SPECIAL LEAD	1
38	621-1744-20	RACK	1	80	716-3635-00	SPECIAL SCREW	1
39	621-1745-20	LOCK ARM L	1	81	293-8575-00	MECH LABEL	1
40	621-1746-20	LOCK ARM R	1	82	SMA-183-200	SLED MOTOR ASSY	1
41	621-1747-20	GEAR COVER	1	83	SMA-200-100	SPINDLE MOTOR ASSY	1
42	621-1748-20	POWER GEAR A	1				

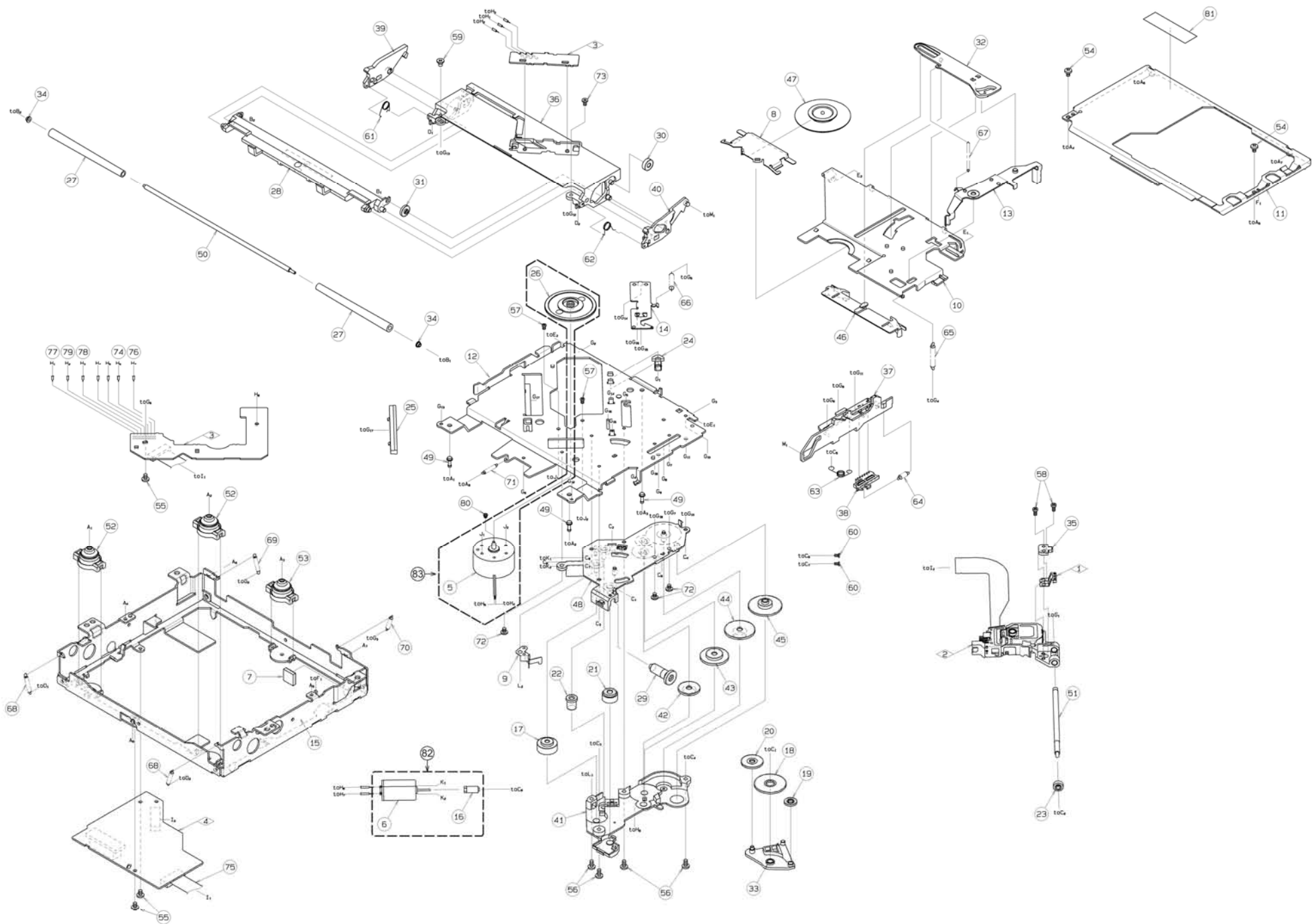

# ELECTRICAL PARTS LIST

## SENS PWB(B1) section

REF No.	PART No.	DESCRIPTION	REF No.	PART No.	DESCRIPTION	REF No.	PART No.	DESCRIPTION
D1	001-7058-90	DIODE	S2	013-7413-50	DETECTOR SWITCH(SPVG12)	J1	074-2215-60	10P
D2	001-7058-90	DIODE	Q1	060-4015-91	PHOTO-TR	PWB	039-2675-20	PWB (WITHOUT COMPONENT)
S1	013-7414-50	DETECTOR SWITCH(SPVG22)	Q2	060-4015-91	PHOTO-TR			

## MAIN PWB(B2) section

REF No.	PART No.	DESCRIPTION	REF No.	PART No.	DESCRIPTION	REF No.	PART No.	DESCRIPTION
C3	168-1052-78	16V 1uF K	C47	166-1011-50	100pF CH	R13	033-3341-15	1/16W 330k ohm J
C6	168-1052-78	16V 1uF K	C48	165-4763-15	6.3V 47uF	R15	033-4731-15	1/16W 47k ohm J
C7	042-0560-85	6.3V 100uF	C49	168-1042-78	16V 0.1uF K	R16	033-3331-15	1/16W 33k ohm J
C8	168-1052-78	16V 1uF K	C50	045-1201-50	12pFJ CH	R17	119-0000-05	1/10W 0 ohm JW
C10	046-1042-78	16V 0.1uF	C51	045-1201-50	12pFJ CH	R18	033-1051-15	1/16W 1M ohm J
C11	168-1042-78	16V 0.1uF K	C71	166-6801-50	68pF CH	R19	033-2221-15	1/16W 2.2k ohm J
C12	166-6801-50	68pF CH	C72	166-6801-50	68pF CH	R20	033-1011-15	1/16W 100 ohm J
C14	046-4722-58	4700pF K B	C73	166-6801-50	68pF CH	R22	119-0000-05	1/10W 0 ohm JW
C17	165-1073-35	16V 100uF	C74	166-6801-50	68pF CH	R24	119-0000-05	1/10W 0 ohm JW
C18	168-1042-78	16V 0.1uF K	C75	166-6801-50	68pF CH	R27	033-0000-05	1/16W 0 ohm
C19	046-1042-78	16V 0.1uF	C76	166-6801-50	68pF CH	R28	033-0000-05	1/16W 0 ohm
C20	046-1532-78	0.015uF K B	C77	166-6801-50	68pF CH	R29	033-0000-05	1/16W 0 ohm
C21	046-1042-78	16V 0.1uF	C78	166-6801-50	68pF CH	R30	033-0000-05	1/16W 0 ohm
C22	168-1042-78	16V 0.1uF K	ET1	073-0792-90	TERMINAL	R31	033-0000-05	1/16W 0 ohm
C23	046-1522-58	1500pF K B	ET2	073-0792-90	TERMINAL	R32	033-0000-05	1/16W 0 ohm
C24	046-1042-78	16V 0.1uF	IC1	051-6751-00	TC94A93MFG-201	R33	033-0000-05	1/16W 0 ohm
C25	046-2222-58	2200pF K B	IC2	051-6101-90	BD8226EFV	R34	033-0000-05	1/16W 0 ohm
C27	168-1042-78	16V 0.1uF K	J1	074-2215-65	15P	R35	033-0000-05	1/16W 0 ohm
C28	043-0559-90	6.3V 22uF	J2	074-2215-60	10P	R36	033-0000-05	1/16W 0 ohm
C29	046-1032-78	16V 0.01uF	J3	074-3032-40	40P	R37	033-0000-05	1/16W 0 ohm
C30	046-4712-58	470pF K B	L1	010-3105-69	80 ohm/100MHz	R38	033-0000-05	1/16W 0 ohm
C31	046-4712-58	470pF K B	L2	010-3105-69	80 ohm/100MHz	R39	033-0000-05	1/16W 0 ohm
C32	046-3332-78	0.033uF K B	L3	010-3105-69	80 ohm/100MHz	R40	033-1041-15	1/16W 100k ohm J
C33	168-1532-55	0.015uF K	L4	010-3105-69	80 ohm/100MHz	R41	033-1011-15	1/16W 100 ohm J
C34	168-1042-78	16V 0.1uF K	Q1	190-2060-00	2SA2060	R42	033-1011-15	1/16W 100 ohm J
C35	166-6801-50	68pF CH	R1	033-2211-15	1/16W 220 ohm J	R44	033-0000-05	1/16W 0 ohm
C36	046-6822-58	6800pF K B	R2	117-6811-15	1/10W 680 ohm	R45	033-4721-15	1/16W 4.7k ohm J
C37	045-4701-50	47pF CH	R3	117-1001-15	1/8W 10 ohm	R46	033-4721-15	1/16W 4.7k ohm J
C38	168-1042-78	16V 0.1uF K	R4	033-1831-15	1/16W 18k ohm J	R47	033-4721-15	1/16W 4.7k ohm J
C39	046-1042-78	16V 0.1uF	R5	033-1231-15	1/16W 12k ohm J	R48	033-4721-15	1/16W 4.7k ohm J
C40	168-1042-78	16V 0.1uF K	R6	033-1541-15	1/16W 150k ohm J	VR1	001-9210-50	AVR- M1608C270MTAAD
C41	046-5622-58	5600pF K B	R7	033-1031-15	1/16W 10k ohm J	X1	061-3572-90	16.92MHZ
C42	168-1042-78	16V 0.1uF K	R8	033-0000-05	1/16W 0 ohm	PWB	039-3723-00	PWB(WITHOUT COMPONENTS)
C43	046-4732-78	16V 0.047uF	R9	033-2211-15	1/16W 220 ohm J			
C44	046-4732-78	16V 0.047uF	R10	033-0000-05	1/16W 0 ohm			
C45	168-1042-78	16V 0.1uF K	R11	033-2231-15	1/16W 22k ohm J			
C46	043-0570-90	16V 2.2uF K	R12	033-4731-15	1/16W 47k ohm J			